

PLUG-IN → PROMOTION

Fiji LDFI-30/31/32 BSA



STANDARD FEATURES

- double devices (two evaporators)
- refrigerant: R290
- working temperature: from 2°C to 4°C
- electrical defrosting
- automatic evaporation of condensate
- electronic controller with temperature indicator
- exposition: zinc-plated steel, powder coated in white (RAL 9003)
- inox square bumper 25 x 25 mm
- color of the base black (RAL 9005)
- sidewalls glass

OPTIONS

- LEDit lighting



FIJI LDFI-31 1600 BSA

BSA — low glass or front glass riser | single, straight | fixed

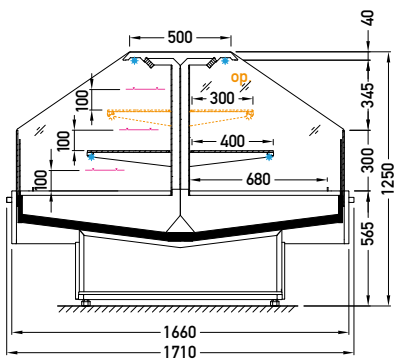

LDFI-32

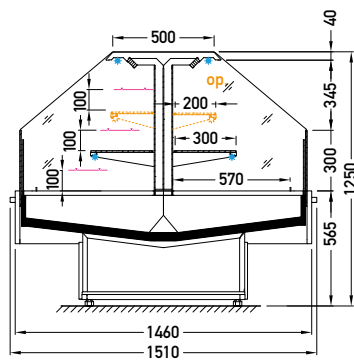

LDFI-31

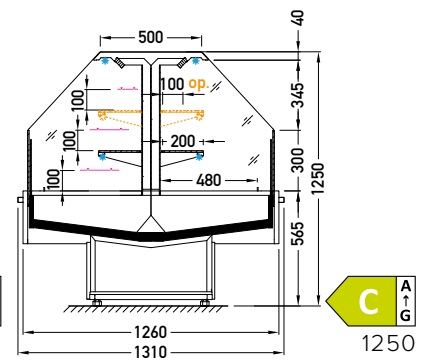

LDFI-30

AVAILABLE MODULES

LDFI-30/31/32 1250 1875 2500

JBG-2 Sp. z o.o. reserves the right to change the standards of devices or to withdraw products without prior notice.

Designation of the energy efficiency class is dedicated to a particular products, which are presented on each page of the catalogue. Indicated energy efficiency class depends on a module type, equipment, glassing version and type of a refrigerant. Amendment of each of the said parameters may cause amendment of the energy efficiency class. Contact the producer to acknowledge the energy efficiency class for the product with different parameters to those presented in the catalogue.